

High Speed Casting Mold for Billet Caster (NS Hyper Mold)

Seisuo KITTAKA*¹
Toshiki SATO*¹

Masatsugu UEHARA*²
Hirohumi HIGASHI*¹

Abstract

The high speed casting technology is an attractive tool to increase the productivity of a billet continuous casting machine. Nippon Steel developed a high-speed stable casting and long life mold called X mold 6 years ago. X mold has gained many customers around the world. Now Nippon Steel has newly developed a higher speed mold called "NS Hyper Mold" which is combined with X mold and other new technologies. This paper presents the splendid results obtained by a billet caster situated at Kyoei Steel in Yamaguchi, where Nippon Steel installed an NS Hyper mold one year ago. These results will lead casting speed for 130 × 130 mm² billet to 6 m/min with excellent high quality.

1. Introduction

High-speed continuous casting of billets has quality problems originating from non-uniform solidification of molten steel in the mold, such as rhombic deformation, off-corner cracks, and breakouts. Off-corner cracks and resultant breakouts are the most serious quality issues. To solve these problems, Nippon Steel Corporation (NSC) developed, in 1993, an X mold with a uniform cooling effect. The X mold helped to solve the problems of rhombic deformation and off-corner cracks resulting from non-uniform solidification of molten steel in the mold^{1,2)}. As improvement on the X mold, NSC then developed the "NS Hyper mold" and used the new mold to continuously cast 130 mm square billets at the high speed of 5 to 6 m/min. The results achieved are reported here. The NS Hyper mold has the following features. 1) High-speed casting: Continuous casting of 130 mm square billets at a speed of 5 m/min, with 6 m/min targeted. 2) High quality: Prevention of rhombic deformation, corner cracks and breakouts, and improvement of surface quality. 3) Operational stability: Stable casting with rapid response to variations in mold level, steel superheat, and casting speed. 4) Long life: Three times longer service life than that of conventional molds.

2. High-speed Casting Tests of Billet Caster at Yamaguchi Works of Kyoei Steel Works, Ltd.

2.1 Causes of and preventive measures for off-corner cracks

Off-corner cracks are formed 5 to 10 mm below the billet sur-

face. Brimacombe et al.³⁾ made a detailed report that these off-corner cracks are caused by bulging in or just below the mold. The following measures are considered to be effective in preventing bulging in and beneath the mold and hence off-corner cracks.

- 1) Prevention of bulging in mold
 - Prevention of delay in corner solidification by uniform cooling in mold: X mold
 - Optimization of mold taper: Double-taper mold
- 2) Prevention of bulging beneath mold
 - Extension of strand support length: Long mold and foot rolls
 - Increase of strand shell stiffness: Intense cooling beneath mold

The Yamaguchi Works of Kyoei Steel Works conducted tests to verify the bulging preventive measures presented above. The tests first optimized the taper of the X mold and then investigated the change to two stages of foot rolls with the mold length unchanged at 800 mm. The equipment specifications are listed in **Table 1**.

2.2 Mold taper optimization

The mold taper optimization test was conducted with 135 by 150 mm billets cast at a speed of 3.5 m/min. The mold was an X mold with a length of 800 mm and a single stage of foot rolls. The calculated solidification shrinkage profile of the strand in the mold is shown in **Fig. 1**. With the conventional mold, the medium-carbon and low-carbon steel differ in the amount of heat removal through the mold and hence in the amount of solidification shrinkage. At the bottom end of the mold, the solidification shrinkage of the medium-carbon

*¹ Plant & Machinery Division

*² ENGINEERING ADVANCEMENT ASSOCIATION OF JAPAN

Table 1 Equipment specifications of billet caster at Kyoji Steel

Ladle	73 t/heat
Steel grade	Low and medium C
Strand No.	3 strands
Machine radius	5 m
Size and speed	135mm × 150mm, max. 3.5m/min 130mm × 130mm, max. 5.0m/min
Mold	X mold, 800 mm long 1 or 2 foot roll stages

Molten steel temperature	T_0	1,433 °C
Shell temperature	T_{1top}	1,190 °C
	$T_{1bottom}$	945 °C
Shell thickness	S_{top}	6.0 mm
	S_{bottom}	9.7 mm
Ferrostatic pressure	P_{top}	0.049 N/mm ²
	P_{bottom}	0.078 N/mm ²

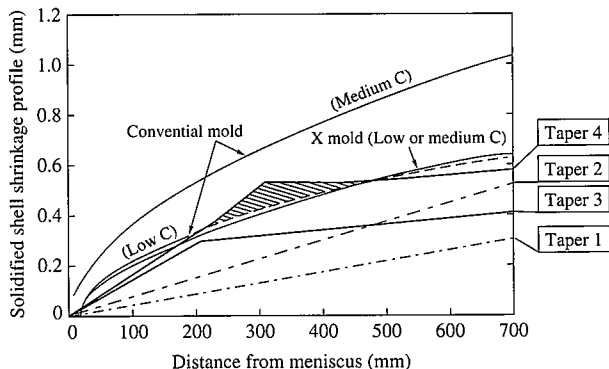

Fig. 1 Solidification shrinkage profile and mold taper (150 mm square billets cast at speed of 3.5 m/min)

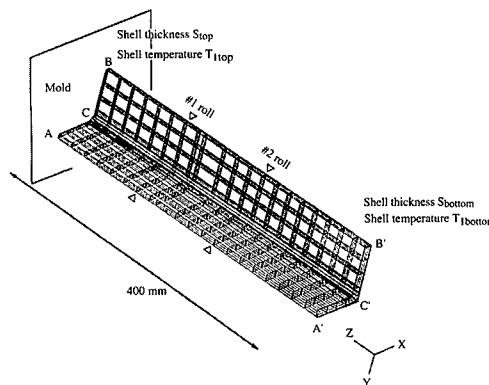

Fig. 2 Bulging analysis model

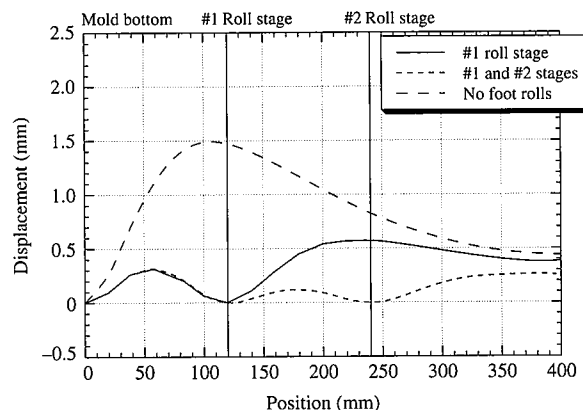

Fig. 3 Bulging displacement on section B-B'

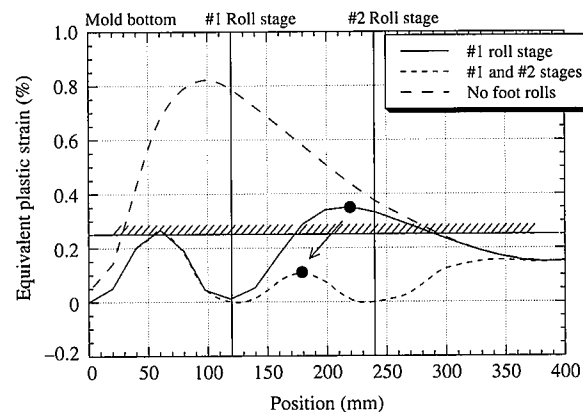

Fig. 4 Bulging strain on section C-C'

steel is about 0.4 mm greater than that of the low-carbon steel. With the X mold, the mild cooling effect of air gaps formed by artificial grooves cut in the mold surface makes the amount of heat removal through the mold approximately equal for the medium-carbon and low-carbon steels, with the result that the two steels have practically the same amount of solidification shrinkage. The amount of solidification shrinkage in the X mold does not depend on the type of steel, so that the taper of the X mold can be easily optimized.

The mold taper optimization test addressed the following four types of taper:

- Taper 1: Single taper, or 0.6%/m
- Taper 2: Single taper, or 1.0%/m
- Taper 3: Double taper, or 2.0 and 0.3%/m
- Taper 4: Double taper, or 2.2 and 0.3%/m

Increasing the mold taper from taper 1 (0.6%/m) to taper 3 (2.0%/m) reduced the incidence of off-corner cracks and attendant breakouts, but not to satisfactory levels. Taper 4 caused hanging-type breakouts in the mold. This suggests that the largest possible mold taper is 2.0%/m. In this test, strands showed off-corner cracks. Any further reduction in the incidence of off-corner cracks after this mold taper optimization calls for prevention of bulging beneath the mold.

2.3 Measures for preventing bulging beneath mold

(1) Analysis of bulging beneath mold

FEM analysis was made of bulging beneath the mold when a 135 mm by 150 mm billet was cast at a speed of 3.5 m/min. The analysis model was a quarter of the cross section of the billet over 400 mm from the bottom end of the mold as shown in Fig. 2. Three cases, or no foot rolls, one foot roll stage, and two foot roll stages, were comparatively studied. The analysis results are given as the bulging displacement on the section B-B' in Fig. 3 and as the bulging strain on the section C-C' in Fig. 4. The bulging displacement is 1.5 mm with no foot rolls, 0.6 mm with one foot roll stage, and 0.3 mm with two

foot roll stages. The bulging strain is 0.8% with no foot rolls, 0.35% with one foot roll stage, and 0.25% with two foot roll stages.

These analysis results suggest that the occurrence of off-corner

cracks with one foot roll stage corresponded to the peak strain of 0.35% downstream of the first of the two foot roll stages (or at 220 mm below the bottom end of the mold). The peak bulging strain of 0.35% can be reduced to 0.1% by installing foot rolls in two stages

Composition of molten steel (%)

C	Si	Mn	P	S
0.12	0.14	0.52	0.031	0.038

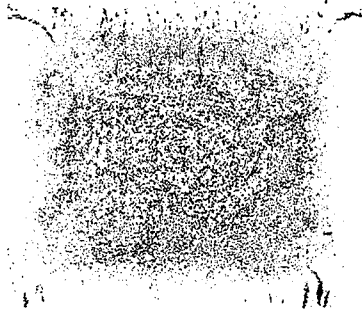

Fig. 5 Printed macrostructure of etched sample of 135 by 150 mm billet cast at speed of 3.5 m/min with one foot roll stage

Composition of molten steel (%)

C	Si	Mn	P	S
0.12	0.14	0.52	0.031	0.038

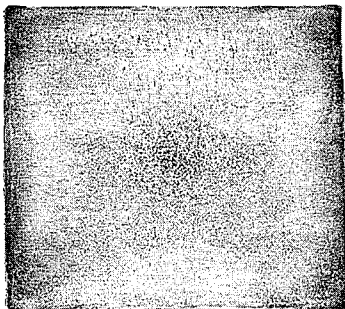

Fig. 6 Printed macrostructure of etched sample of 135 by 150 mm billet cast at speed of 3.5 m/min with two foot roll stage

Composition of molten steel (%)

C	Si	Mn	P	S
0.12	0.14	0.52	0.031	0.038

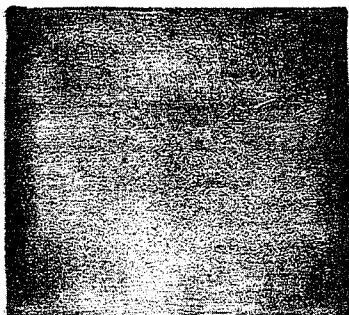

Fig. 7 Printed macrostructure of etched sample of 130 mm square billet cast at speed of 4.8 m/min with two foot roll stages

and increasing the intensity of spray water cooling.

(2) Two-foot roll stage test

The two-foot roll stage test was conducted, based on the bulging analysis results. The test results were quite satisfactory, with 135 by 150 mm and 130 mm square billets being stably cast at high speeds of 3.7 and 5.0 m/min, respectively. The printed macro-structures of etched samples are shown in Figs. 5 to 7. Off-corner cracks and resultant breakouts occurred at a rate of 8 times/month with one foot roll stage, but practically disappeared with two foot roll stages. According to these test results, the largest permissible bulging strain below which off-corner cracks can be prevented was put at 0.25%.

3. Estimation of Casting Speed as Constrained by Mold Length

High-speed billet casting calls for the mold length to be increased to prevent bulging directly below the mold. If the mold length is increased too much, on the other hand, the friction resistance in the mold increases the possibility of the shell rupturing at the mold exit. That is, the minimum and maximum possible mold lengths for high-speed casting are constrained by prevention of bulging and by prevention of shell rupturing due to the in-mold friction, respectively. The maximum casting speed possible under these mold length constraints is studied for 130 mm square billets as described below.

(1) Mold length and number of foot roll stages as required to prevent bulging beneath mold

The mold length and the number of foot roll stages as required to prevent the bulging of 130 mm square billets are given in Table 2.

Table 2 Mold length and foot roll conditions required to prevent of bulging of 130 mm square billets

Casting speed	Required mold length	Foot roll
4.5 m/min	L ≥ 800 mm	2 stages
	L ≥ 1,000 mm	None
6.0 m/min	L ≥ 1,000 mm	2 stages
8.0 m/min	L ≥ 1,400 mm	2 stages

The analysis results of bulging beneath the mold of 130 mm square billets cast at speeds of 4.5, 6.0, and 8.0 m/min are shown in Figs. 8 to 10, respectively. The following can be known from these analysis results.

When the casting speed is 4.5 m/min, the bulging strain is large at about 0.6% with the mold length of 800 mm and with no foot rolls. Installation of foot rolls in two stages reduces the bulging strain to less than the maximum permissible strain of 0.25%. When the mold length is 1,000 mm, the bulging strain can be held below the maximum permissible level of 0.25%, even without foot rolls. When the casting speed is 6.0m/min, the mold length of 1,000 mm and two foot roll stages are required. When the casting speed is 8.0 m/min, the mold length of 1,400 mm and two foot roll stages are required to prevent bulging beneath the mold.

(2) Maximum possible mold length as constrained by friction resistance in mold and prevention of breakouts

Kimura et al.⁴⁾ reported the following simplified equation for the condition under which the solidified shell would not rupture (or break out) due to the friction resistance in the mold (see Fig. 11):

$$\text{Shell rupture strength} > \text{Frictional force in mold due to ferrostatic pressure of molten steel}$$

$$4 \cdot S \cdot W \cdot \sigma_B > 1/2 \cdot \gamma_0 \cdot L_0^2 \cdot 4W \cdot \mu$$

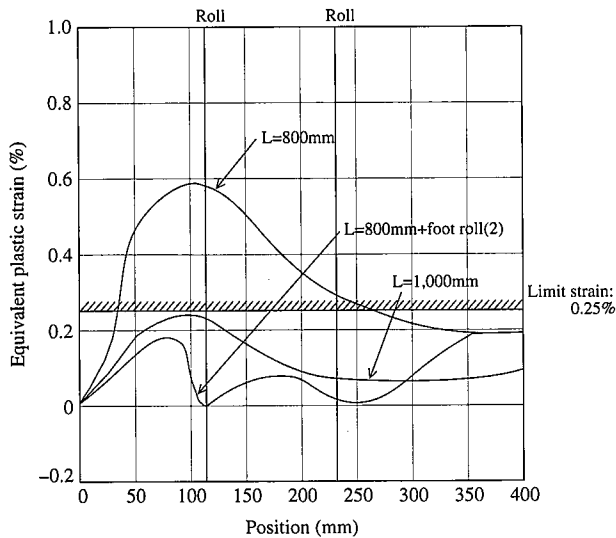

Fig. 8 Bulging beneath mold of 130 mm square billets cast at speed of 4.5 m/min

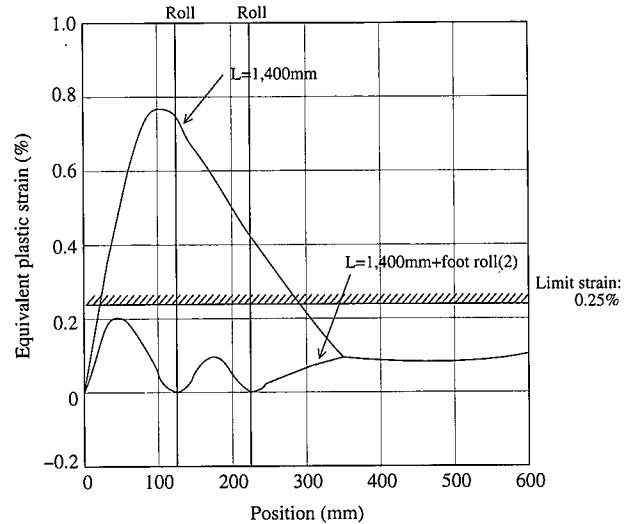

Fig. 10 Bulging beneath mold of 130 mm square billets cast at speed of 8.0 m/min

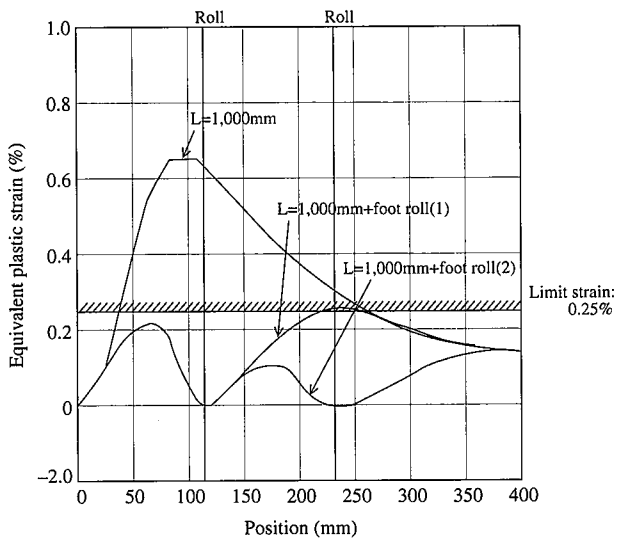

Fig. 9 Bulging beneath mold of 130 mm square billets cast at speed of 6.0 m/min

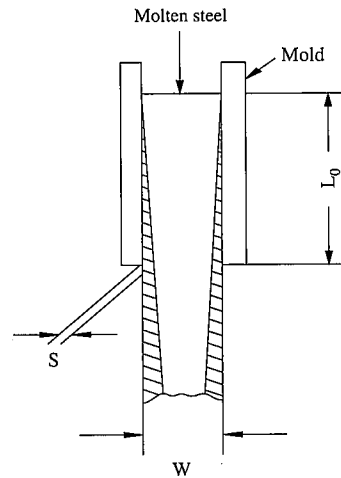

Fig. 11 In-mold friction resistance

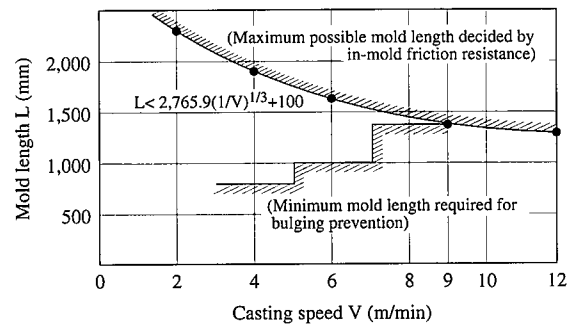

Fig. 12 Minimum mold length required to prevent bulging beneath mold and maximum possible mold length dictated by in-mold friction resistance

where S = shell thickness = $13.8 \sqrt{(L_0 \times 10^{-3} / V)}$ mm; W = billet size, mm; σ_b = shell rupture stress at $1,250^\circ\text{C} = 11.76 \text{ N/mm}^2$; γ_0 = specific gravity of molten steel = $0.00007056 \text{ N/mm}^3$; μ = shell/mold friction coefficient = 1.0; V = casting speed, m/min; L_0 = actual mold length, mm; and L = mold length = $L_0 + 100$ mm.

Solution of the above equation gives the maximum possible mold length L as constrained by the casting speed. Since no reliable values are available about the in-mold friction coefficient μ during high-speed continuous billet casting, the value of reported by Umeda et al.⁵⁾ for chromium-plated molds was used.

Maximum possible mold length $L < 2,765.9(1/V)^{1/3} + 100$ (mm)

Fig. 12 shows the minimum mold length required to prevent bulging and the maximum possible mold length constrained by the in-mold friction resistance, as calculated by the above equations. According to these results, the maximum casting speed is governed by the mold length and estimated at about 9.0 m/min. A more detailed

study calls for in-depth investigation of the in-mold friction resistance.

4. Modification to Higher Casting Speed of Billet Caster at Kansai Billet Center Co., Ltd.

4.1 Equipment specifications of modified billet caster

Nippon Steel is modifying the production capacity per strand of the continuous billet caster at Kansai Billet Center Co., Ltd. from 27 t/h to 48 t/h (equivalent to 130 mm square billets cast at a speed of 6 m/min). The revamped caster is scheduled for operation in August 1999 (see Table 3).

4.2 Achievement of maximum casting speed by prevention of bulging beneath mold

The bulging of billets is prevented by using a long mold and two stages of foot rolls and by intensely cooling the strand beneath the mold. Fig. 13 shows the bulging analysis results of 150 mm square billets cast at a speed of 4.6 m/min. High-speed casting uses a long mold to prevent bulging beneath the mold. When a 900-mm long

Table 3 Equipment specifications of modified billet caster at Kansai Billet Center

	Before modification	After modification
1. Ladle	120 t	Same
2. Number of strands	6 strands	Same
3. Tundish capacity	16 t	25 t
4. Steel grade	Midium and low C	Same
5. Size and speed	150mm × 150mm, 2.6m/min 165mm × 165mm, 2.2m/min 185mm × 185mm, 1.8m/min	Maximum 150mm × 150mm, 4.6m/min 165mm × 165mm, 3.8m/min 185mm × 185mm, 3.2m/min
6. Mold	800 mm long	NS Hyper Mold 900 mm long + 2 foot roll stages
7. Meniscus control	Thermocouple system	Same (γ-ray system/provisional)
8. Secondary cooling	• 1,200 L/min • 2 zones	• 2,200 L/min • 3 zones
9. Hydraulic shear		Increased cutting speed

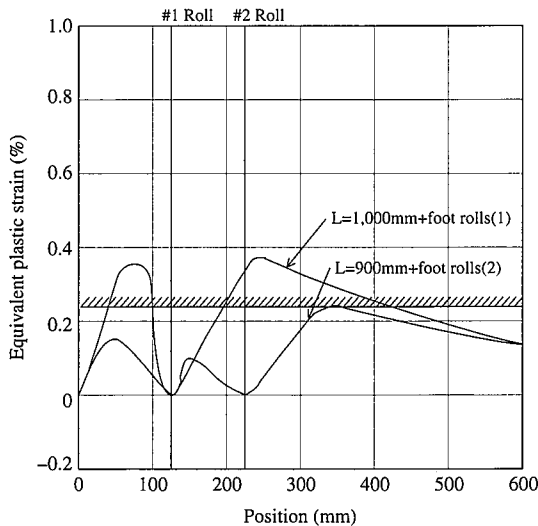

Fig. 13 Bulging beneath mold of 150 mm square billets cast at speed of 4.6 m/min

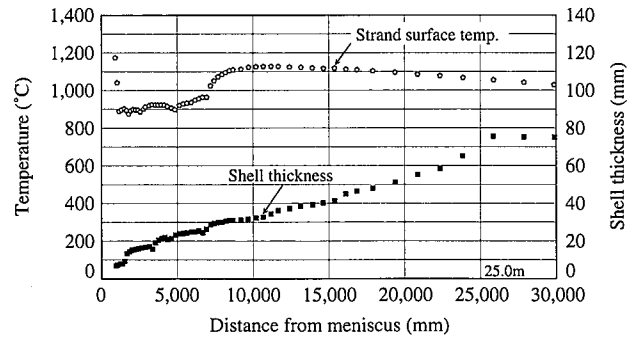

Fig. 14 Secondary cooling temperature of 150 mm square billets cast at speed of 4.6 m/min

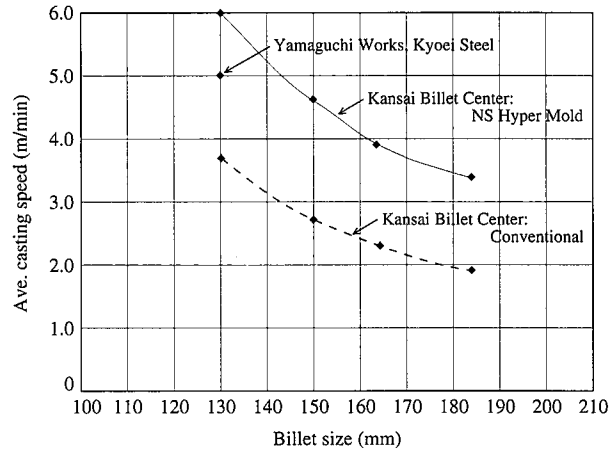

Fig. 15 Billet size and casting speed

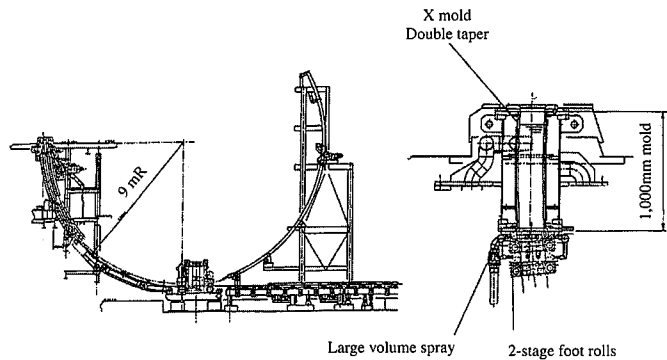

Fig. 16 Schematic of modified billet caster at Kansai Billet Center

mold is used, foot rolls are installed in two stages to limit the bulging strain to 0.25% or less. Fig. 14 shows the strand surface temperature and solidifying shell thickness in the casting direction. The growth of a strong shell is ensured by such intense cooling that the strand surface temperature is kept constant beneath the mold. Fig. 15 shows the relationship between the billet size and casting speed. The equivalent production rate is 130 mm square billets cast at a speed of 6.0 m/min. Fig. 16 schematically illustrates the modified billet caster at Kansai Billet Center.

5. Conclusions

- 1) Prevention of off-corner cracks and breakouts during high-speed

continuous billet casting calls for optimization of mold taper and prevention of bulging beneath the mold.

- 2) The NS Hyper mold can continuously cast 130 mm square billets at a speed of 5.0 m/min without occurrence of off-corner cracks and breakouts.
- 3) The maximum possible casting speed is governed by the mold length that is in turn constrained by prevention of bulging and in-mold friction resistance. This maximum possible casting speed is estimated at about 9.0 m/min.
- 4) The continuous billet caster of Kansai Billet Center Co., Ltd. is being modified for casting 150 mm square billets at a speed of 4.6 m/min, 165 mm square billets at a speed of 3.8 m/min, and 185 mm square billets at a speed of 3.2 m/min (equivalent to 130 mm square billets cast at a speed of 6.0 m/min). The revamped

caster is scheduled for operation in August 1999.

The authors would like to thank the Yamaguchi Works of Kyoei Steel Works, Ltd. and Kansai Billet Center Co., Ltd. for cooperation in the preparation of this paper.

References

- 1) Sato, T.: High-Speed Casting of Continuous Cast Billet by X Mold. SE AISI 1996 Thailand Conference, Vol. 1-6/1, 1996
- 2) Uehara, M.: High-Speed Billet Casting by X Mold at Yamaguchi Works, Kyoei Steel Company. SE AISI 1997 Korea Conference, Vol. 2-16/1, 1997
- 3) Brimacombe, J. K. et al.: Formation of Off-Corner Internal Cracks in Continuously-Cast Billet, Canadian Metallurgical Quarterly. 19, 215-227(1980)
- 4) Kimura, T.: 69·70th Nishiyama Memorial Seminar, Specific continuous caster. 1980, p.358
- 5) Umeda, Y. et al.: Tetsu-to-Haganè. 4, 243(1979)